

CERWIN-VEGA!®

CVHF – POWERED SUBWOOFERS FOR HOME

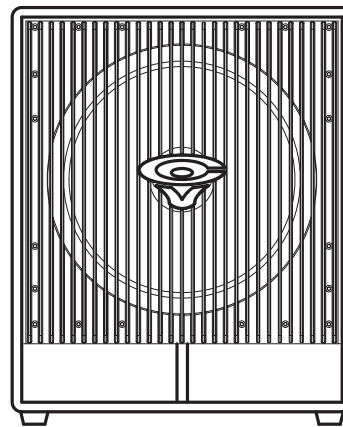
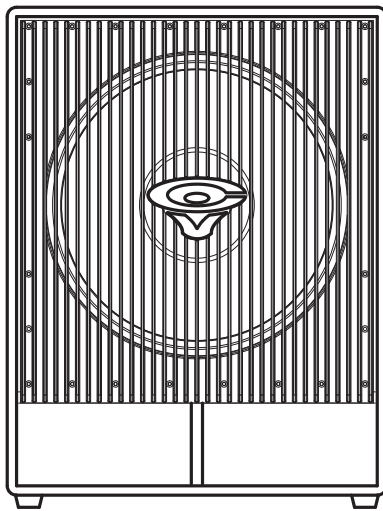

CERWIN-VEGA'S LIMITED WARRANTY

WELCOME TO THE FAMILY!

First off, you have great taste in loudspeakers. At Cerwin-Vega!, deep bass and great highs are a way of life. Nice to know there are a few people out there who share our passion for music. You'll be glad to know that this company has been in business since 1953. And we consider you to be the newest member of the family.

We hope your speakers give you years of enjoyment. Of course, in the event of a problem, make sure you familiarize yourself with this warranty. We like to think that while you're sitting in front of your speakers, we're standing behind them. And now a few choice words from our lawyer. (Hey, every family has one).

WHO'S COVERED BY THIS WARRANTY?

Cerwin-Vega's Limited Warranty on residential speakers extends only to the original purchaser as evidenced by the original Bill of Sale and only to the residential speakers purchased from authorized Cerwin-Vega! dealers.

Ten words of advice: *Retain the original bill of sale, in a safe place!*

WHAT'S COVERED BY THIS WARRANTY?

Cerwin-Vega! warrants that all new residential speakers shall be free from defects in material and workmanship, under normal and proper use. Cerwin-Vega! agrees to repair or replace (at our option) all such defective parts at no charge for labor or materials.

WHAT'S NOT COVERED BY THIS WARRANTY?

This Limited Warranty does not apply to defective equipment that: has been altered or repaired by other than factory approved procedures; has been subjected to negligence, misuse or accident; has been damaged by improper line voltage; had its serial number or any part of it altered, defaced, or removed; has been used for other than home entertainment purposes; or has been used in a way that is contrary to Cerwin-Vega's written instructions.

Except as provided by statute, this Limited Warranty does not cover losses, consequential or otherwise, resulting from the improper use of, or inability to operate, any Cerwin-Vega! product.

HOW LONG DOES THE WARRANTY EXTEND?

Cerwin-Vega's Limited Warranty extends for a period of (2) years for all system speaker components, two (2) years for all associated electronics components, including amplifier and controller devices, and one (1) year for speaker stands and wall mount brackets, from the date of purchase as shown on the original Bill of Sale.

The warranty period will be extended if the warranty repairs have not been performed due to delays caused by Cerwin-Vega! or a representative of Cerwin-Vega!, or if the warranty repairs did not remedy the defect and the original purchaser notifies Cerwin-Vega! or the original dealer or an Authorized Cerwin-Vega! Service Center of the failure of the repairs within 30 days after they were completed.

HOW DO YOU GET WARRANTY SERVICE?

In order to obtain warranty service, contact your original dealer or distributor, or an Authorized Cerwin-Vega! Service Center. If, for some reason, you have trouble locating a service representative, contact Cerwin-Vega's Customer Service Department for assistance:

Cerwin-Vega! Customer Service Dept.
772 S. Military Trail
Deerfield Beach, FL 33442
+1 (954) 949-9601
service@cerwin-vega.com

In some cases, the Customer Service Department can solve a service problem without any return of equipment, thereby avoiding transit delays. For more information visit http://www.cerwin-vega.com/service_support.php

WHAT IF THE PRODUCT MUST BE RETURNED?

If the Customer Service Department determines that the equipment must be returned to Cerwin-Vega! for service, a Return Authorization will be issued by mail, and the defective merchandise may be shipped directly to the above address freight prepaid, along with a copy of both the Return Authorization and the original Bill of Sale.

The product will be replaced or repaired (at our option) and returned to the original purchaser. Only the return postage will be paid by Cerwin-Vega! Cerwin-Vega! will not be responsible for damage occurring in shipment from the original purchaser or due to improper packing materials. Remember to pack all equipment carefully and in the original carton if possible. Additional charges may be added if new packing materials are required for return shipment. Save your original packing materials!

WHAT ARE OTHER REMEDIES UNDER THE LAW?

The exercise of any of the provisions under the Limited Warranty does not affect the protections or remedies of the original purchaser under other laws. If you have additional questions about service, write or call the Customer Service Department. This Limited Warranty applies to all residential speakers, and supersedes all previous warranty statements. Cerwin-Vega! reserves the right to make changes in product design and specifications at any time.

EXCEPT AS PROVIDED HEREIN AND BY APPLICABLE LAW, CERWIN-VEGA! MAKES NO ADDITIONAL REPRESENTATION OR WARRANTY OF ANY NATURE WHATSOEVER, EXPRESSED OR IMPLIED, AS TO THE EQUIPMENT, INCLUDING BUT NOT LIMITED TO, THE MERCHANTABILITY, FITNESS FOR A PARTICULAR PURPOSE, DESIGN CONDITION OR WORKMANSHIP OF THE EQUIPMENT, OR THE QUALITY OF THE MATERIAL INCLUDED THEREIN, THIS LIMITED WARRANTY CONSTITUTES THE SOLE AND ENTIRE AGREEMENT BETWEEN CERWIN-VEGA! AND THE ORIGINAL PURCHASER.

IMPORTANT SYMBOLS AND SAFETY INSTRUCTIONS

Explanation of Graphic Symbols



The exclamation point within an equilateral triangle is intended to alert the users to the presence of important operating and maintenance (servicing) instructions in the literature accompanying the product.



The lightning flash with the arrowhead symbol, within an equilateral triangle, is to alert the user to the presence of insulated "dangerous voltage" within the products enclosure that may be of sufficient magnitude to constitute a risk of electric shock to humans.



CAUTION: TO REDUCE THE RISK OF ELECTRONIC SHOCK - DO NOT REMOVE COVER. NO USER SERVICEABLE PARTS INSIDE. REFER SERVICING TO QUALIFIED PERSONNEL.



ATTENTION: POUR EVITER LES RISQUES DE CHOC ELECTRIQUE, NE PAS ENLEVER LE COUVERCLE. AUCUN ENTRETIEN DE PIECES INTERIEURES PAR L'USAGER. CONFIER L'ENTRETIEN AU PERSONNEL QUALIFIE. AVIS: POUR EVITER LES RISQUES D'INCENDIE OU D'ELECTROCUTION, N'EXPOSEZ PAS CET ARTICLE A LA PLUIE OU A L'HUMIDITE.

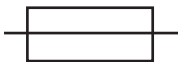

The IEC fuse symbol pictured at the left represents an approved user replaceable fuse. When replacing a fuse, make sure to replace with only the correct type and rating.

Important Safety Instructions

1. Read and keep these instructions.
2. Heed all warnings and follow instructions.
3. Do not use this apparatus near water.
4. Clean only with a dry cloth.
5. Do not block any ventilation openings.
6. Do not install near any heat sources such as radiators, heat registers, stoves, or other apparatus that produce heat.
7. Do not defeat the safety purpose of the polarized or grounding type plug. A polarized plug has two blades with one wider than the other. A grounding-type has two blades and a third grounding prong. The wide blade or the third prong is provided for your safety. If the provided plug does not fit your outlet, consult a electrician for replacement of the obsolete outlet.
8. Protect the power cord from being pinched, particularly at plugs, convenience receptacles, and the point where they exit.
9. Only use attachments / accessories specified by the manufacturer.
10. Use only with a cart, stand, bracket, or table specified by the manufacturer or sold with the apparatus. When a cart is used, use caution when moving the cart / apparatus combination to avoid injury from tip-over.
 
11. Unplug this apparatus during lightning storms or when unused for long periods of time.
12. Refer all servicing to qualified service personnel. Servicing is required when a apparatus has been damaged in any way, such as power-cord or plug is damaged, liquid has been spilled, or objects have fallen into the apparatus, the apparatus has been exposed to rain or moisture, does not operate normally, or has been dropped.
13. To reduce the risk of fire or electric shock, do not expose this apparatus to rain or moisture.
14. The apparatus shall be connected to a main socket outlet with a protective connection.
 - a) Mains plug is used as the disconnect device. It shall remain readily operable and should not be obstructed during intended use.
 - b) The apparatus shall not be exposed to dripping or splashing and that no objects filled with liquids, such as vases, shall be placed near / on the apparatus.

CONTENTS

1. Introduction 1
 1.1 Before You Begin 1
2. Overview of Controls 2
3. Placing the Subwoofer 3
4. Wiring the Subwoofer 4
5. Troubleshooting 6
6. Specifications 7

1. INTRODUCTION

Congratulations! Welcome to the Cerwin-Vega! family. You've joined a growing group of audio enthusiasts who've turned to Cerwin-Vega! for the most advanced audio reproduction systems available. All Cerwin-Vega! systems are thoroughly tested to insure that they meet or exceed our performance specifications. Backed by the best service in the industry, Cerwin-Vega! is dedicated to quality and reliability. For a complete overview of Cerwin-Vega! products and services, please visit our website at www.cerwin-vega.com

1.1 BEFORE YOU BEGIN

Cerwin-Vega! subwoofers are easily capable of generating sound pressure levels (SPL) sufficient to cause permanent hearing damage to performers, production crew and audience members. Caution should be taken to avoid prolonged exposure to SPL in excess of 90 dB.

Built-in Amplifier Precautions

Do not attempt to service this unit beyond instructions contained in this manual. Refer all servicing to a Cerwin-Vega! / Stanton Authorized Service Center. Servicing is required when the apparatus has been damaged in any way, such as power-supply input connector is damaged, liquid has been spilled or objects have fallen into the apparatus, the apparatus has been exposed to rain or moisture, does not operate normally, or has been dropped. Keep your Cerwin-Vega! subwoofer amplifier module away from sources of heat, such as a radiator or oven. Do not cover or surround your Cerwin-Vega! subwoofer amplifier module with material that may retain heat, such as a blanket or curtain. Be certain that the vents on the panel of the amplifier module are clear of all obstructions during operation.

Warning

- Shock Hazard: To reduce risk of fire or electric shock, do not expose this unit to rain or moisture.
- Do not immerse your Cerwin-Vega! subwoofer amplifier module in any liquid.
- Do not operate your Cerwin-Vega! subwoofer near a pool, bathtub or other standing water.
- Do not bypass or defeat the grounding or polarization means used on the Cerwin-Vega! subwoofer amplifier module.
- Make sure all blades on the polarized power plug can be fully inserted into the receptacle or other outlet that will be used with the unit.
- Your Cerwin-Vega! subwoofer amplifier module should be cleaned only with a dry cloth.
- Take care of the power cord attached to your Cerwin-Vega! subwoofer amplifier module. Avoid situations where your cord might be stretched, pinched, or otherwise abused. Route it to avoid foot traffic. Pay special attention to the cord connector and attachment points.

2. OVERVIEW OF CONTROLS (Figure 2.1)

INDICATORS: Illumination of LED indicates status of amplifier.

- Power = electric current is live and present in the system
- Limit = the system is being driven to its maximum capacity (clipping)
- Protect = the built-in amplifier has shut down to protect itself
- Signal = a line-level signal is present in the system

IN L & R inputs: Electronically balanced XLR and RCA connectors accept input signal from line-level sources. IN L & R also routes to THRU L & R outputs.

LEVEL: Controls the master volume at the pre-amp stage.

HIGH PASS FILTER: When sending a full range signal through the subwoofer to top cabinet, the HPF blocks LF signals below indicated frequencies from reaching the top cabinet.

VARIABLE LOW PASS FILTER: When sending a full range signal to the subwoofer, the variable LPF blocks HF signals above indicated frequencies from reaching the subwoofer. In the fully count.

THRU L & R outputs: Provide a loop-thru of the signals coming in on the L and R inputs. The High Pass filter is active on these outputs. These outputs and the High Pass filter area always active regardless of whether the unit is in master or slave mode. Typically these outputs are used for top cabinets.

POLARITY SWITCH: Changes the polarity of the subwoofer, also referred to as the “phase.” Listen and adjust for maximum bass.

MASTER / SLAVE: This mode is used to provide the ability to adjust multiple sub units from the master sub. When switched to MASTER, all sub controls are functional and both L and R inputs are operational. The LINK OUT connector sums the input signals from both L and R inputs and is used to send a signal to a sub in SLAVE mode. When set to SLAVE mode, only the L input connector is active and the LEVEL, POLARITY, and LOW PASS FILTER are inactive. To attach more subs, set them to SLAVE mode, use the LINK OUT of the previous sub, and send this signal to the L IN on the SLAVE.

LINK OUT: Used to send a signal to a sub set to SLAVE mode. When the sub is set to SLAVE mode, the LINK OUT provides a summed signal of the L and R inputs. (See MASTER / SLAVE for more information).

PARAMETRIC EQUALIZER (CVHF-A21S only): One band full parametric equalizer with adjustment of the Gain, Frequency, and Q. The higher the setting, the narrower the frequency range becomes that is being affected.

POWER SWITCH: Turns the AC power of the unit On and Off.

AC INPUT: Input for attachment of the IEC power cord.

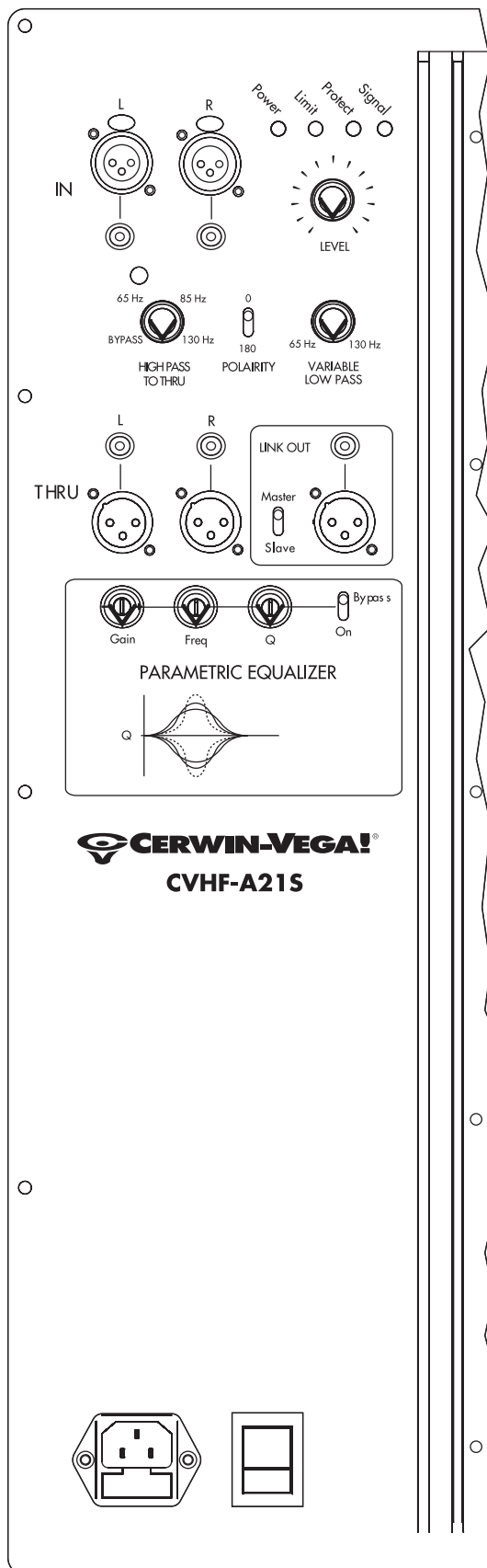

Figure 2.1

3. PLACING THE SUBWOOFER (Figure 3.1)

Proper placement of your subwoofer will result in the best musical and home theater experience. Thankfully, subwoofer placement is not difficult.

Subwoofers reproduce low-frequency audio. Low frequencies are not as directional as high frequency signals, so unlike placing high-frequency speakers subwoofers can usually be placed anywhere in the room.

When you put a subwoofer in a room, the sound waves bounce back and forth between the parallel surfaces of the room. When they combine, it is possible to get a "standing wave." If they cancel each other out you can get a null. If you listen in a location where standing waves peak, you will likely hear boomy, one-note bass. If you are sitting in a null, you will hear less bass. Moving a foot or two to either side of a null can cause the bass to "magically" reappear.

As you can see, the subwoofer and your particular room work together. It's not just the location of the subwoofer that matters: where you place the sofa and chairs is just as important. Here are a few tricks that will help you work around peaks and nulls and assist you in getting the best sound from your subwoofer.

If possible, place the subwoofer on the same horizontal plane as your main speakers, i.e. in line with them.

Corners and walls reinforce bass frequencies. If possible, place the subwoofer in the corner of a room or next to a wall, and then use the subwoofer's level control to dial in the right amount of bass.

The worst place for a subwoofer is in the middle of a room. There are no walls to reinforce the bass energy there.

If there is too much bass buildup in one area, try moving furniture around to dissipate, or diffuse, this buildup. Careful subwoofer and furniture placement will help to more evenly distribute the bass frequencies throughout the room. A second subwoofer can also be used to more evenly distribute bass frequencies, though is usually not necessary.

The most difficult room shape is square, so if you have the flexibility to choose which room you'll use for home theater or you are building a new home and designating a space for home theater, avoid rooms with equal dimensions.

The closer you sit to a wall, the more pressure your ear will pick up and the greater the bass intensity will be.

Avoid rooms with concrete floors and walls. Walls where the wallboard flexes are more absorptive and produce fewer problems with "bass boom." If you can't avoid concrete walls, add studs and one layer of wallboard to the walls of the room to further aid absorption.

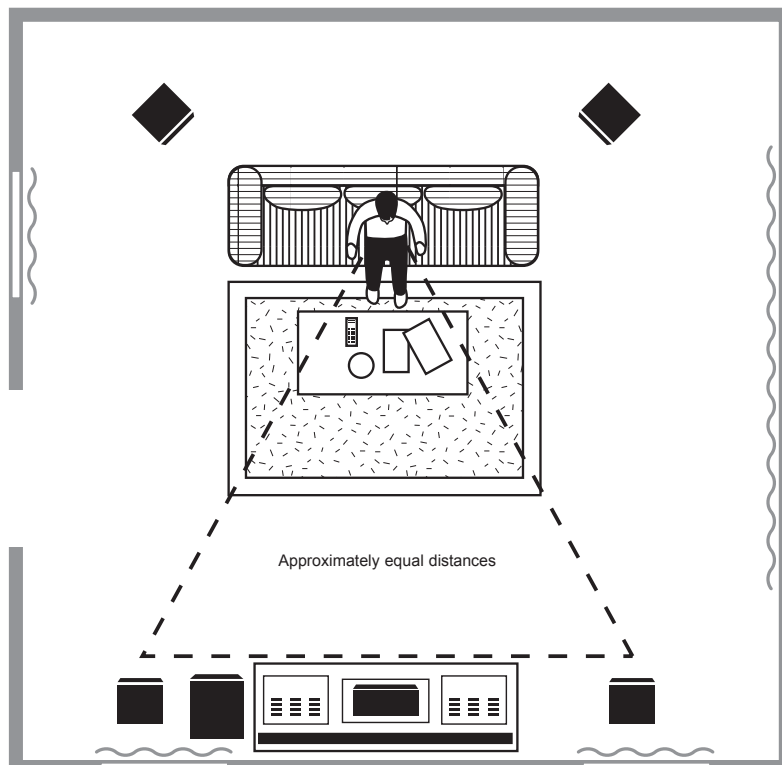

Figure 3.1

4. WIRING THE SUBWOOFER

Option 1: LFE (Figure 4.1)

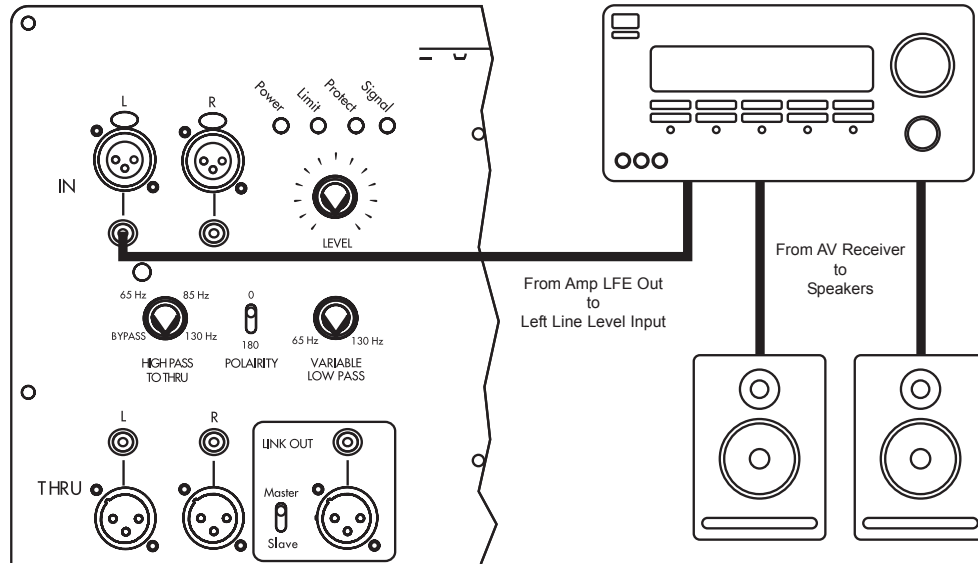

Figure 4.1

Option 2: Line Level Input (no LFE) (Figure 4.2)

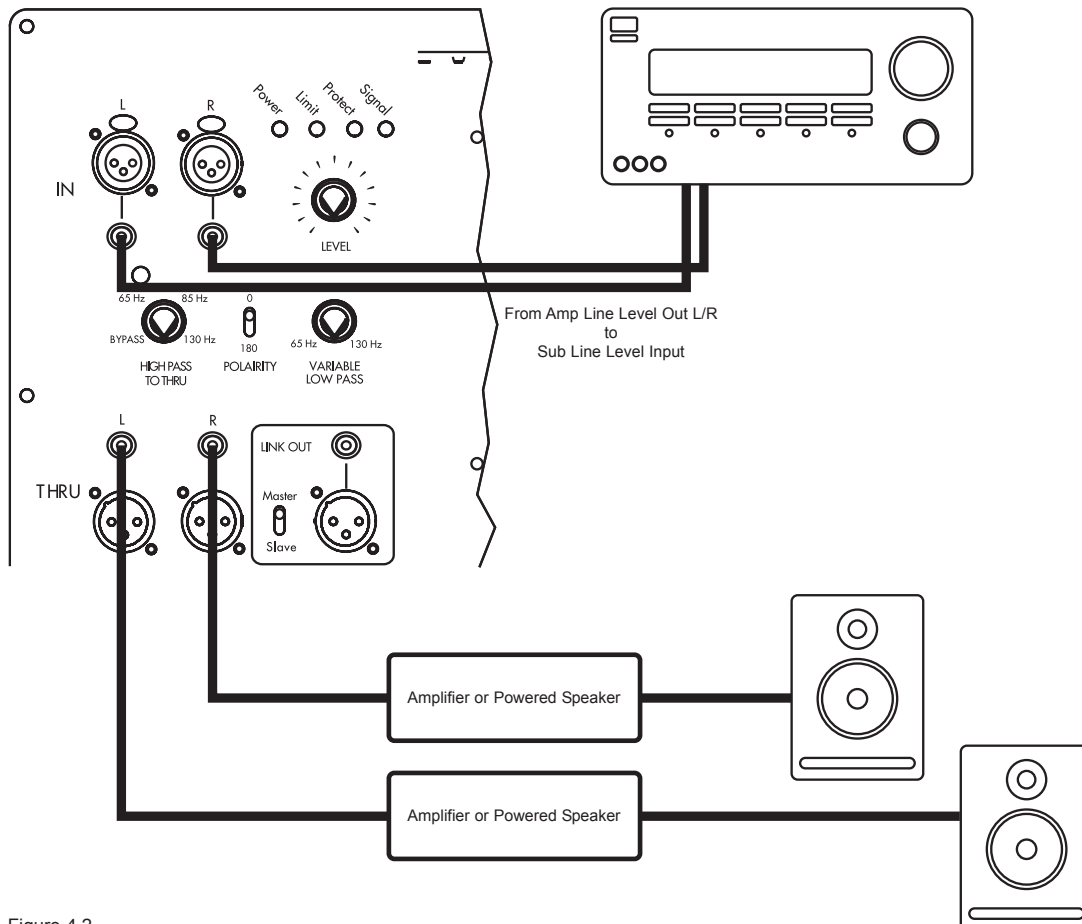

Figure 4.2

Cerwin-Vega! CVHF - Powered Subwoofers for Home

Option 3: Adding and additional sub (Figure 4.3)

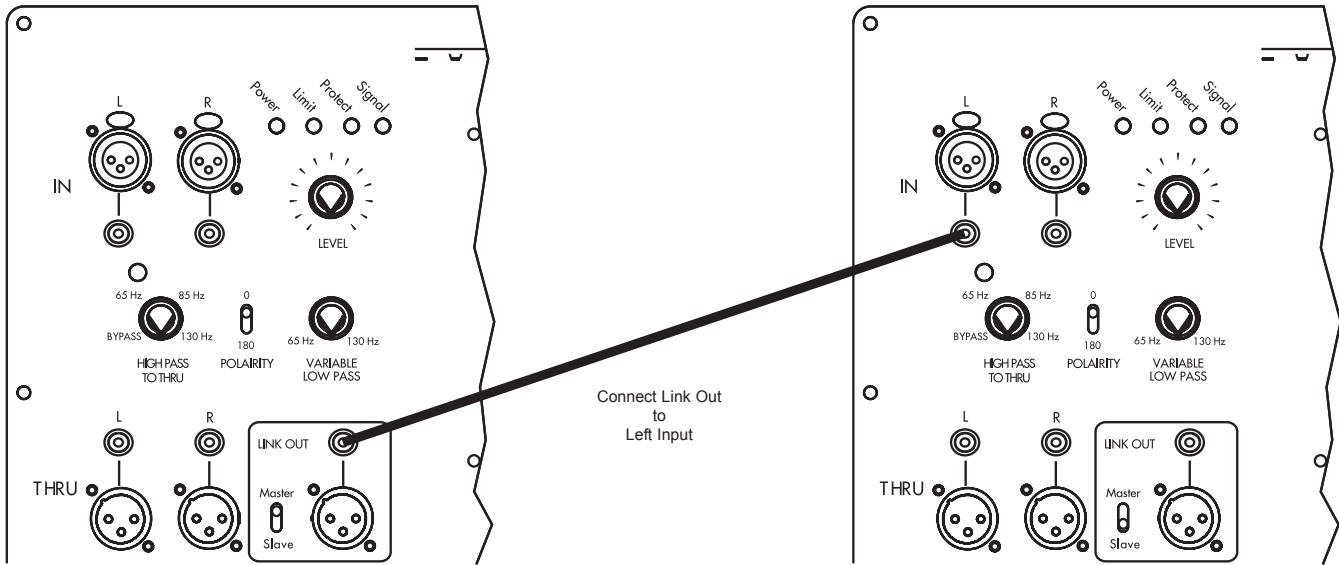

Figure 4.3

Note: XLR connections can be used in place of the RCA.

5. TROUBLESHOOTING

Symptoms	Causes	Solutions
Bass sounds distorted	Amplifier is at maximum output Receiver tone controls are set too high	Lower volume or receiver level control Set bass flat; use tone controls sparingly
Distortion with volume control near minimum	Defective receiver or preamplifier, or shorted speaker wires	Repair defective receiver, preamplifier or replace speaker wires
Distortion on music peaks or sound effects	Dynamic soundtrack (e.g., explosions)	Turn down volume control to lower overall range
Buzz, hum, or crackle when connecting wires	Connecting wires with power on causes transient signal spikes	Connect wires only when system power is Off
Buzz or hum when system is On	Grounding problem or ground loop	Check receiver or preamplifier manual for help in eliminating a ground loop
No sound after listening at high-levels	Amplifier's thermal protection has been temporarily activated	Lower subwoofer volume and allow amplifier to cool down; sound should resume automatically

6. SPECIFICATIONS

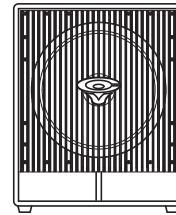
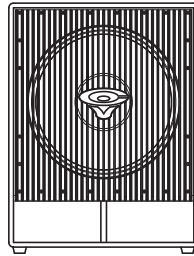

Subwoofer	CVHF-A21S	CVHF-A18S
Description	21 inch Active Subwoofer	18 inch Active Subwoofer
Frequency Response	35 Hz - 120 Hz	36 Hz - 120 Hz
Frequency Range	(-10 dB) 1: 28 Hz – 150 Hz	(-10 dB) 1: 28 Hz – 150 Hz
Power (continuous / peak watts)	1200 / 2400	700 / 1400
Crossover	Variable LPF: 65 Hz to 130 Hz HPF: 25 Hz	Variable LPF: 65 Hz to 130 Hz HPF: 25 Hz
Controls	HPF: 65 Hz, 85 Hz, 130 Hz Variable LPF: 65 Hz, 130 Hz Polarity Switch, 0 - 180	HPF: 65 Hz, 85 Hz, 130 Hz Polarity Switch, 0 - 180
Parametric Equalizer	Gain, Frequency, Q	N/A
LF Driver	21" Paper cone double roll cast frame woofer	18" Paper cone double roll cast frame woofer
Input Connectors	L&R XLR/RCA In and Through XLR/RCA Link Out	L&R XLR/RCA In and Through XLR/RCA Link Out
Dimensions (H x W x D)	31.7 inch x 24.1 inch x 23.3 inch 803 mm x 610 mm x 592 mm	25.7 inch x 21.1 inch x 23.7 inch 653 mm x 534 mm x 602 mm
Net Weight	194.5 lb / 88.3 kg	125.5 lb / 57 kg

All information included in this User Manual is subject to change without notice.



772 S. Military Trail • Deerfield Beach, FL 33442

Phone: +1 (954) 949-9601

Fax: +1 (954) 949-9590

E-mail: info@cerwin-vega.com

www.cerwin-vega.com